

THE ALL IN ONE

HORIZON

TECHNICAL
MANUAL

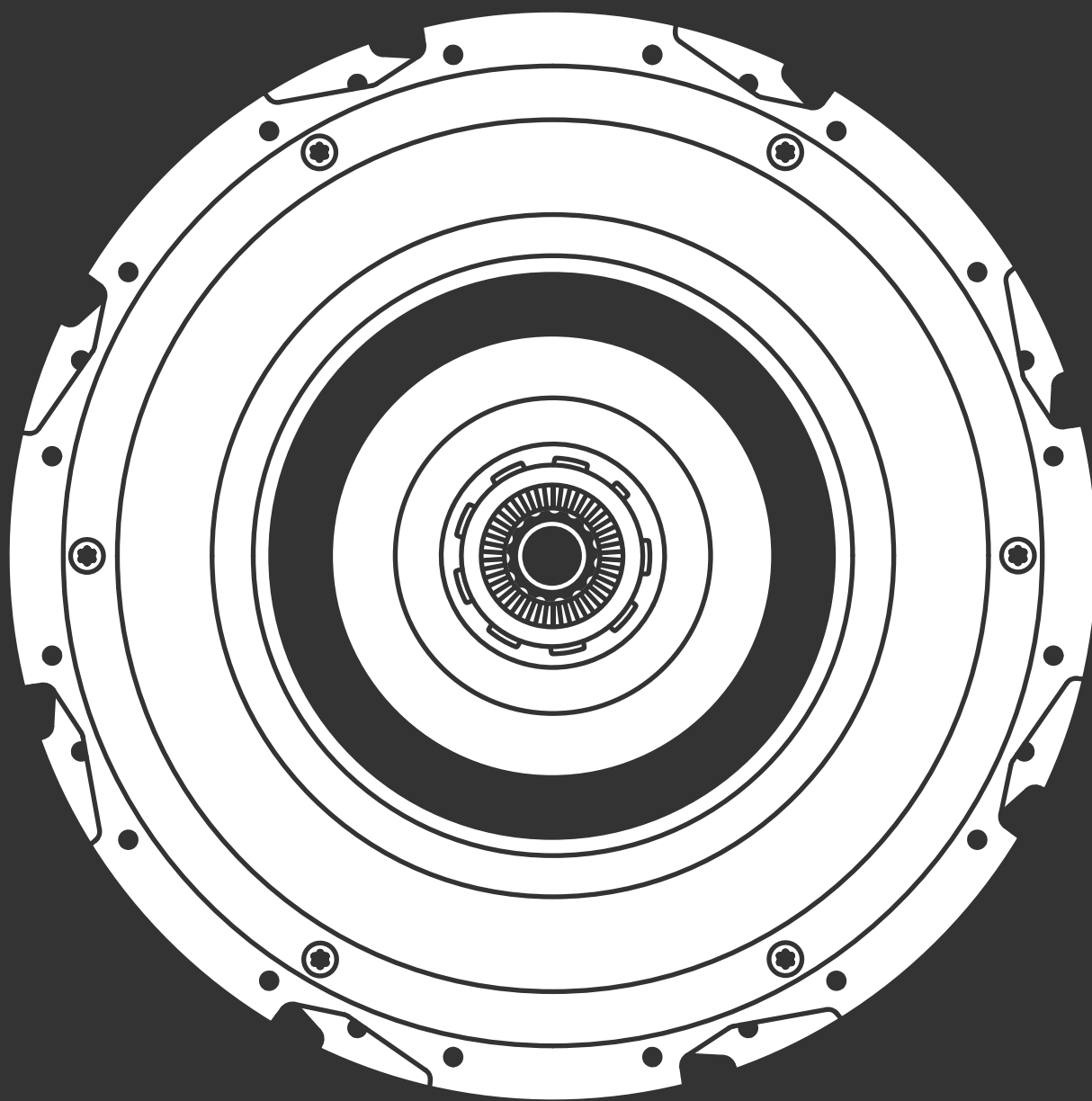

ZEXUS

The All In One Horizon Technical Manual
Rev. 1.4 - 03/2024

Contents

1. Introduction	4
1.1 Differences between 2.0 and 2.1	4
1.2 How to check my product generation?	4
2. Technical specifications	5
2.1 The All In One specifications	5
2.2 Charger specifications	5
3. Wheel dimensions	6
4. Lacing specifications	7
4.1 Rim brake (single speed)	7
4.2 Roller brake	9
4.3 Disc brake (single speed)	11
4.4 Spoke length calculation	13
5. Frame building guidelines	14
5.1 Rear dropout design and compatibility	14
5.2 Torque arm design	18
5.3 Chain stays and seat stays design	21
5.4 Disc brake caliper compatibility	22
5.5 Disc rotor compatibility	22
5.6 Disc brake mount dimensions	23
5.7 Rollerbrake® compatibility	23
6. Assembly instructions	24
6.1 Content of the box	24
6.2 Wheel building (lacing)	24
6.3 Mounting the wheel on the frame	26
7. Sprockets and gearbox compatibility	30
7.1 Lockring and lockring tools	30
7.2 Gearbox systems	32
8. Battery care	32
8.1 Charging	32
8.2 Storage conditions	33
8.3 Transport	33
8.4 Disposal	33
TECHNICAL MANUAL	2

This document contains detailed information about The All In One Horizon (formerly Horizon) model year 2021 (Gen 2.1) by Zehus.

1. Introduction

This manual contains detailed information about Zehus The All In One Horizon, formerly Bike products, how to build a bike frame compatible with this product and how to install it on a bike.

1.1 Differences between 2.0 and 2.1

Zehus all in one Generation 2 are divided in:

- Generation 2.0: in these products, the mechanical design is inherited by Generation 1.x motors.
- Generation 2.1: these products feature major design reviews on the mechanical side. Please double check if you purchased Generation 2.1 Zehus all in one.

1.2 How to check my product generation?

Please check Zehus P/N on the order confirmation. The 5th char is referring to your system's generation:

P/N: YB991XXX – Generation 1.2

P/N: YB991XXX – Generation 2.0

P/N: YB992XXX – Generation 2.1

2. Technical specifications

2.1 The All In One specifications

Motor

Rated power	250 W
Maximum torque	40 Nm

Battery

Cells	18650
Rated voltage	33,6 V
Rated capacity	6000 mAh
Rated energy	173 Wh

Hub

Weight	3,3 kg
Operating temperature*	-10 to +40 °C
Storage temperature**	0 to +40 °C
Charging temperature	0 to +40 °C
Protection degree	IP X4

**Operating temperature is limited by software*

*** Optimal storage temperature is 23°C*

2.2 Charger specifications

Voltage input	100-240 V, 50/60 Hz
Voltage output	33,6 V
Charging current	2A
Charging time	3 h

3. Wheel dimensions

In the following table it is reported the wheel dimension related to The All In One hub size.

Please check the product that suits the intended application before ordering.

The All In One size	Wheel circumference (mm)	
	<i>Min</i>	<i>Max</i>
S	1265	1620
M	1900	2050
L	2060	2340

Attention: changes have been made since the previous The All In One model, check again the compatibility of your application to order the correct size.

4. Lacing specifications

4.1 Rim brake (single speed)

Front view

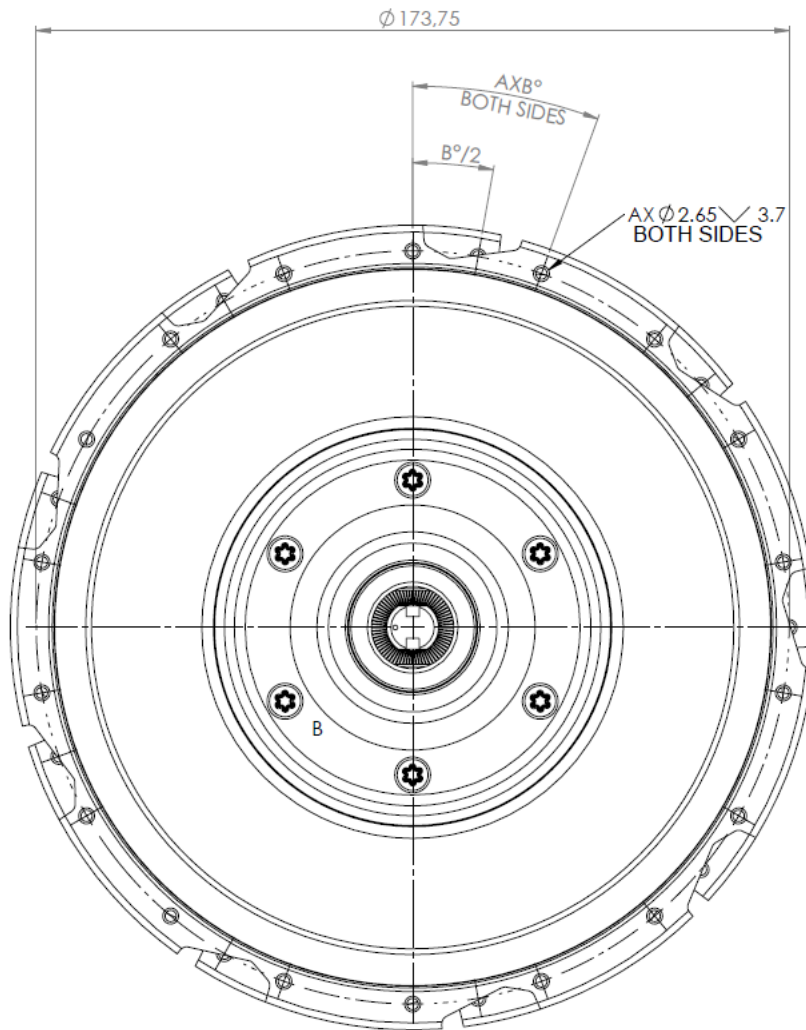

Holes	PCD (mm)	A	B
32	$\varnothing 173,75$	16	$22,5^\circ$
36	$\varnothing 173,75$	18	20°

*dimensions are in mm

Side view

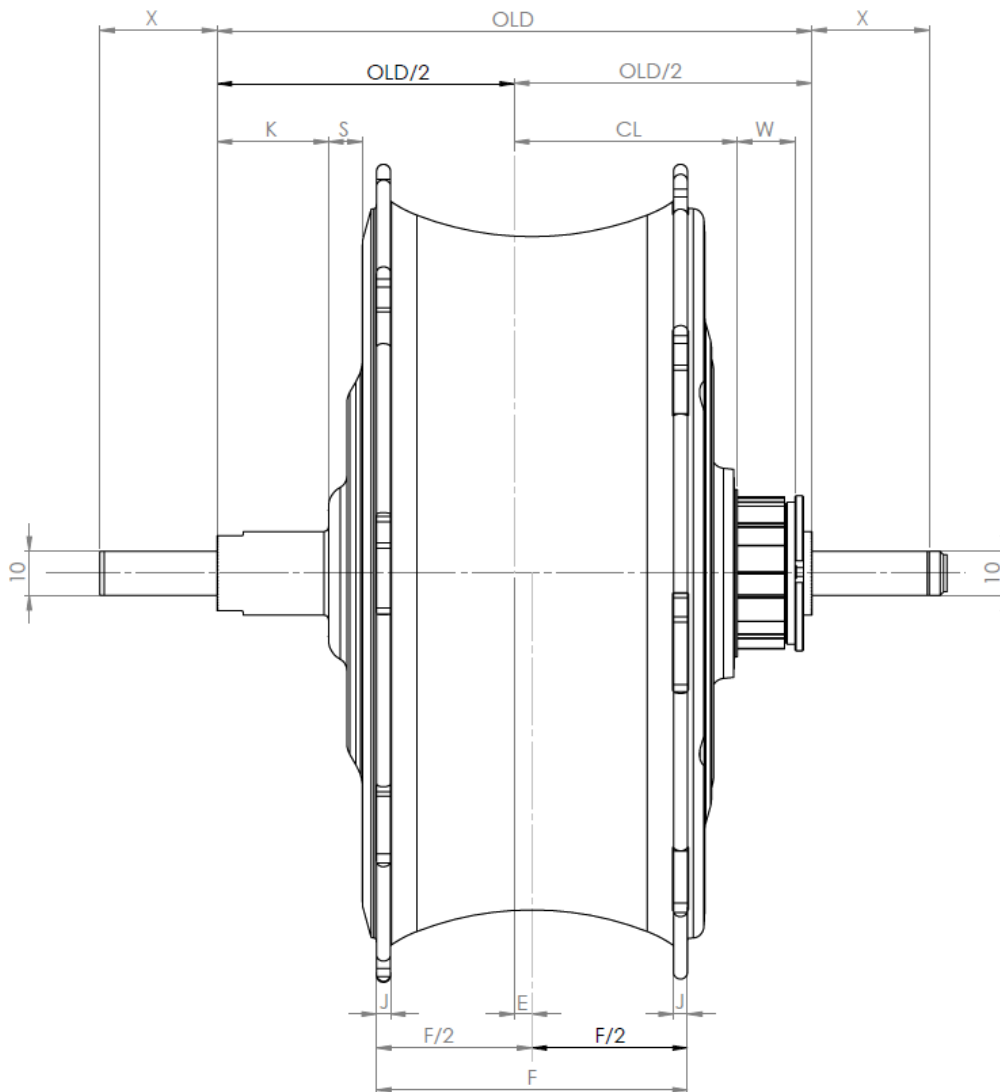

Speed	OLD	CL	W	E	F	J	K	S	X
1	120	50,6	13,1	4,0	70,6	3,2	17,8	7,7	26,6
1	135	50,6	13,1	4,0	70,6	3,2	25,3	7,7	26,6

*dimensions are in mm

FREEWHEEL is a Shimano Splines freewheel with custom lockring (provided by Zehus). For single speed applications, CHAINLINE can be adapted from "CL" mm for the length of the freewheel "W" using standard spacers.

4.2 Roller brake

Front view

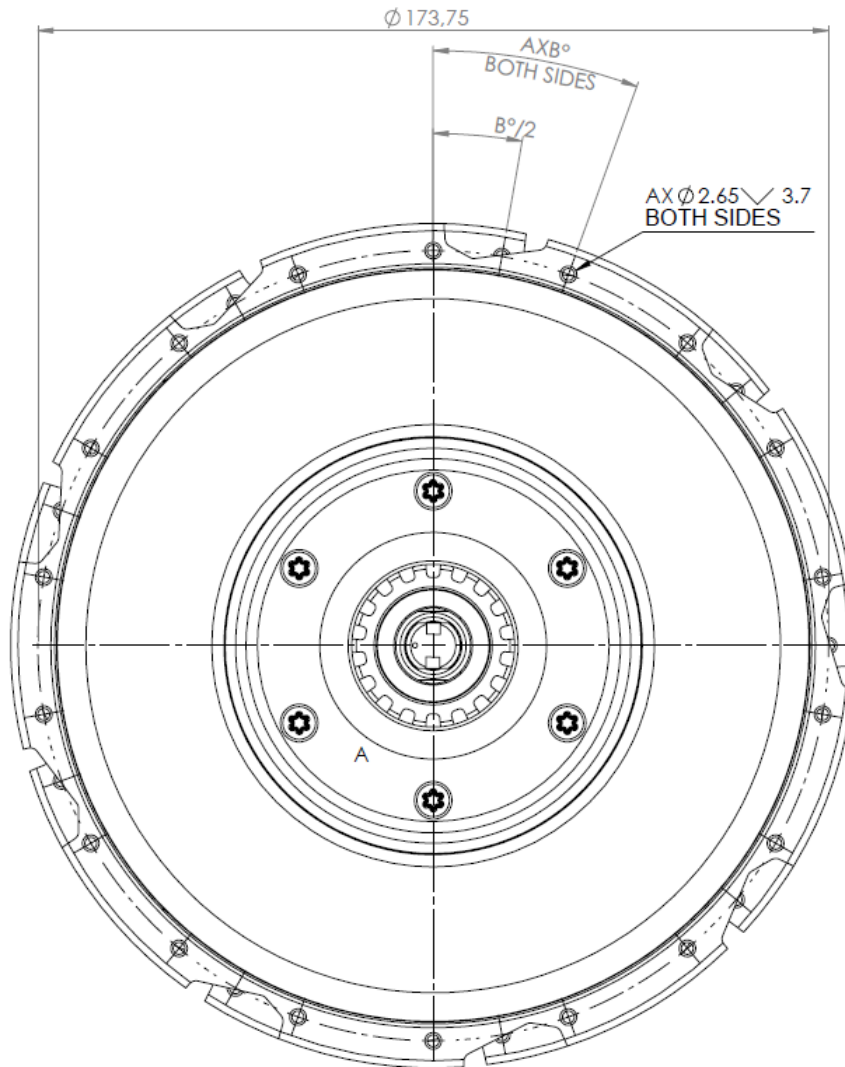

Holes	PCD (mm)	A	B
32	ø173,75	16	22,5°
36	ø173,75	18	20°

*dimensions are in mm

Side view

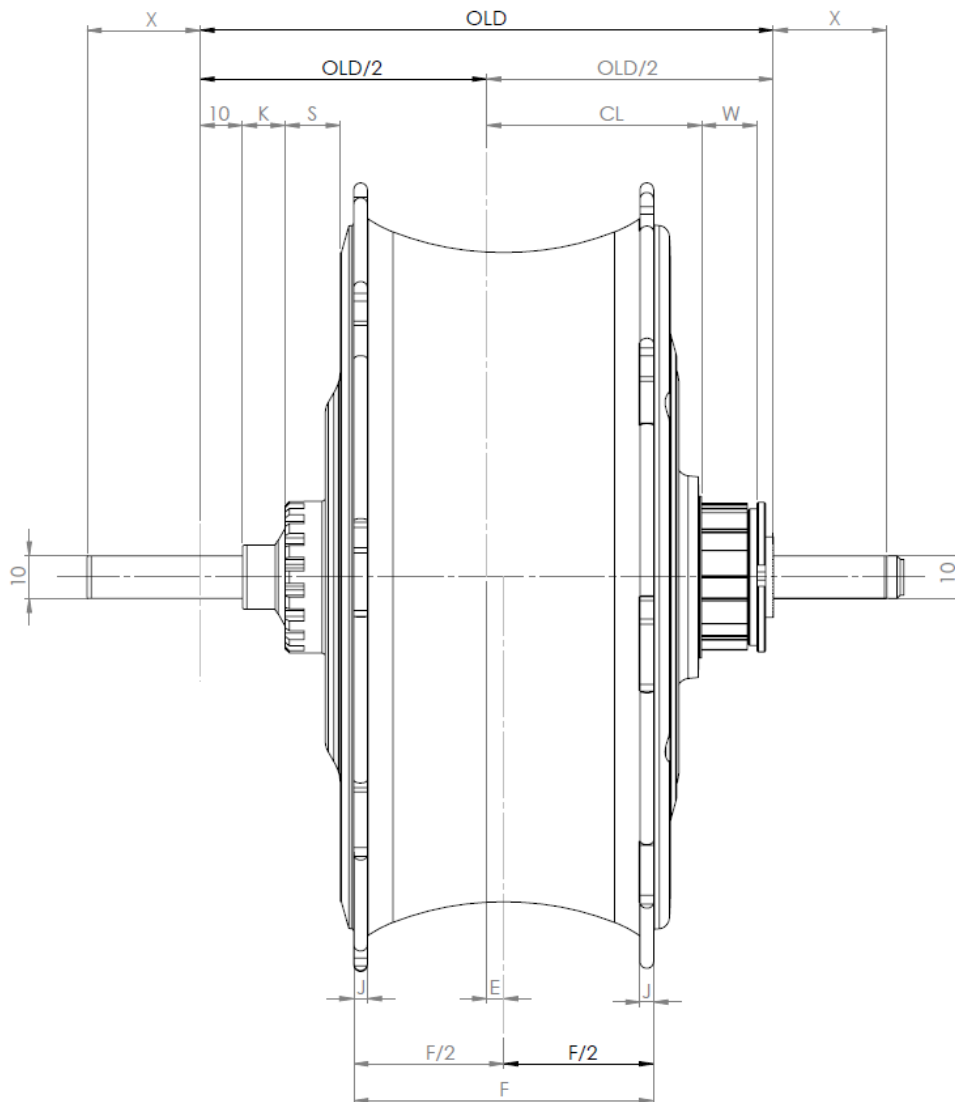

Speed	OLD	CL	W	E	F	J	K	S	X
1	135	50,6	13,1	4,0	70,6	3,2	11,0	12,0	26,6

*dimensions are in mm

FREEWHEEL is a HG Splines freewheel with custom lockring (provided by Zehus). For single speed applications, CHAINLINE can be adapted from "CL" mm for the length of the freewheel "W" using standard spacers.

4.3 Disc brake (single speed)

Front view

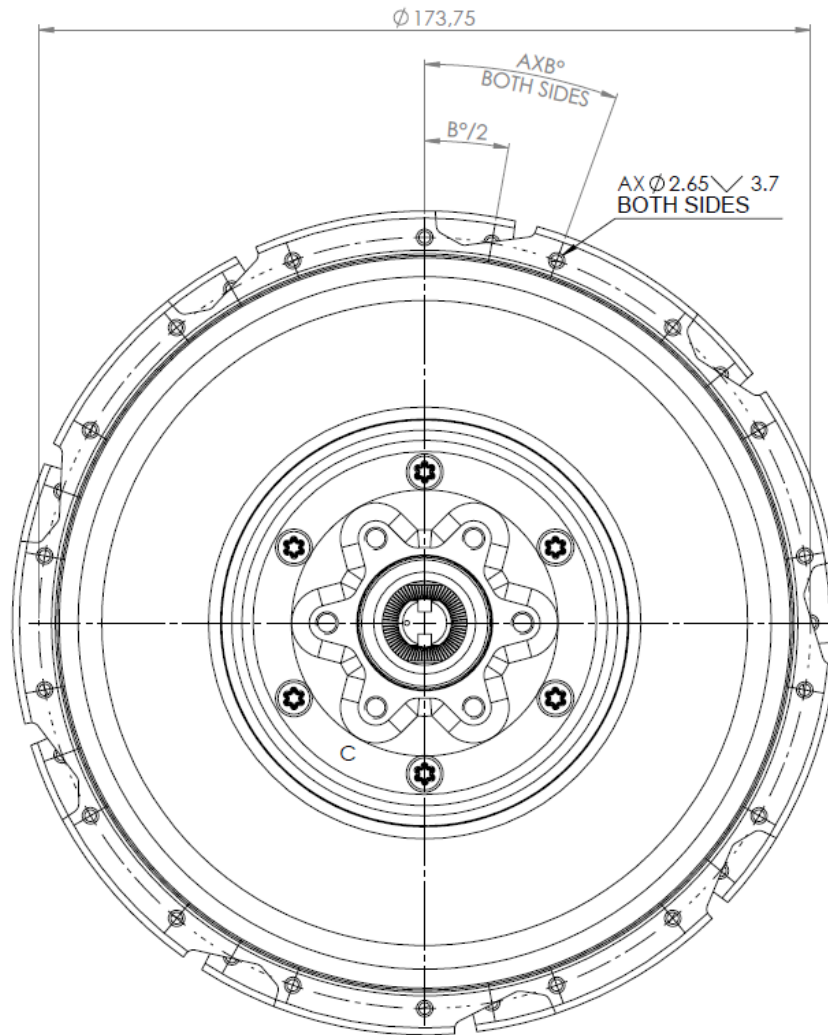

Holes	PCD (mm)	A	B
32	$\phi 173,75$	16	22,5°
36	$\phi 173,75$	18	20°

*dimensions are in mm

Side view

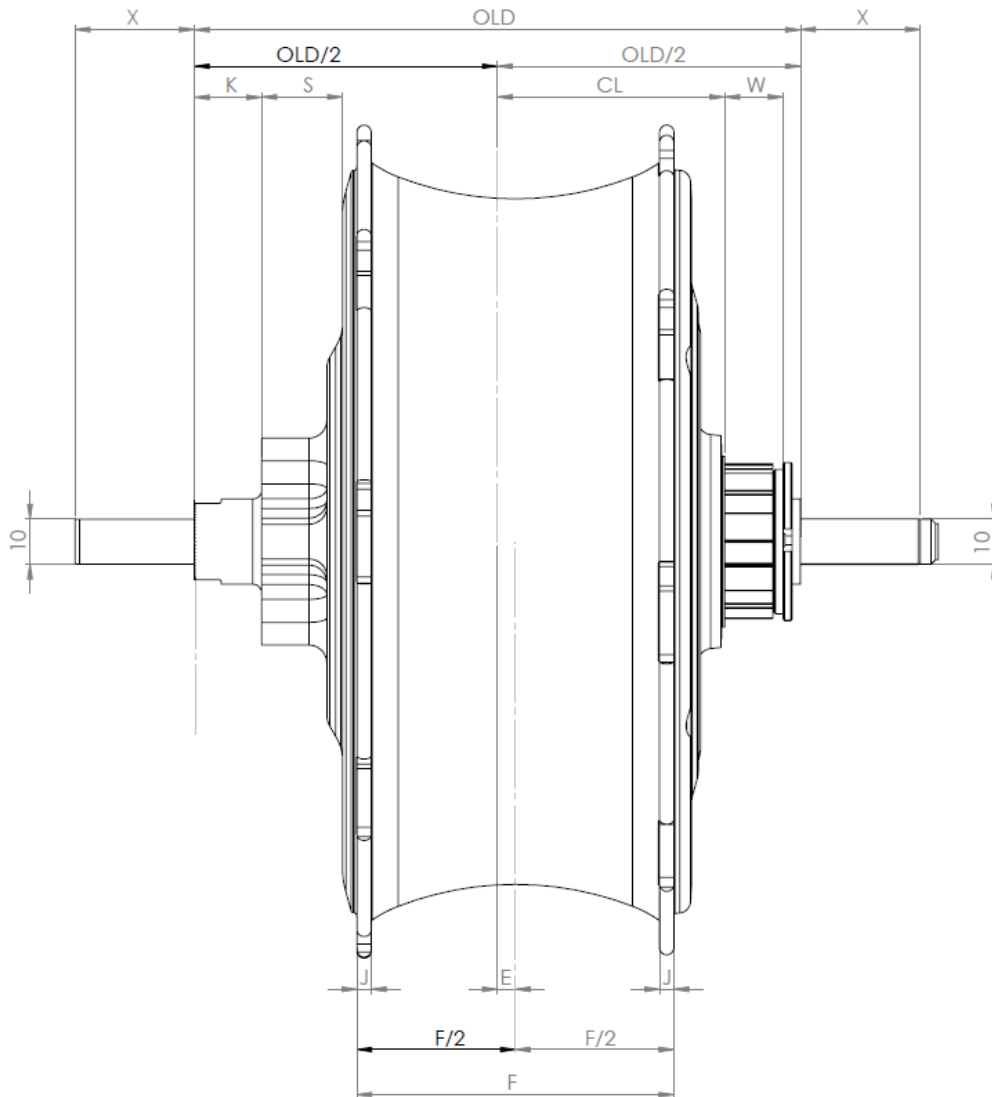

Speed	OLD	CL	W	E	F	J	K	S	X
1	135	50,6	13,1	4,0	70,6	3,2	15,0	18,0	26,6

*dimensions are in mm

FREEWHEEL is a HG Splines freewheel with custom lockring (provided by Zehus). For single speed applications, CHAINLINE can be adapted from "CL" mm for the length of the freewheel "W" using standard spacers. All dimensions are in mm.

4.4 Spoke length calculation

To calculate the correct spokes length through the online calculation tools it is necessary to consider these dimensions according to the hub version of interest.

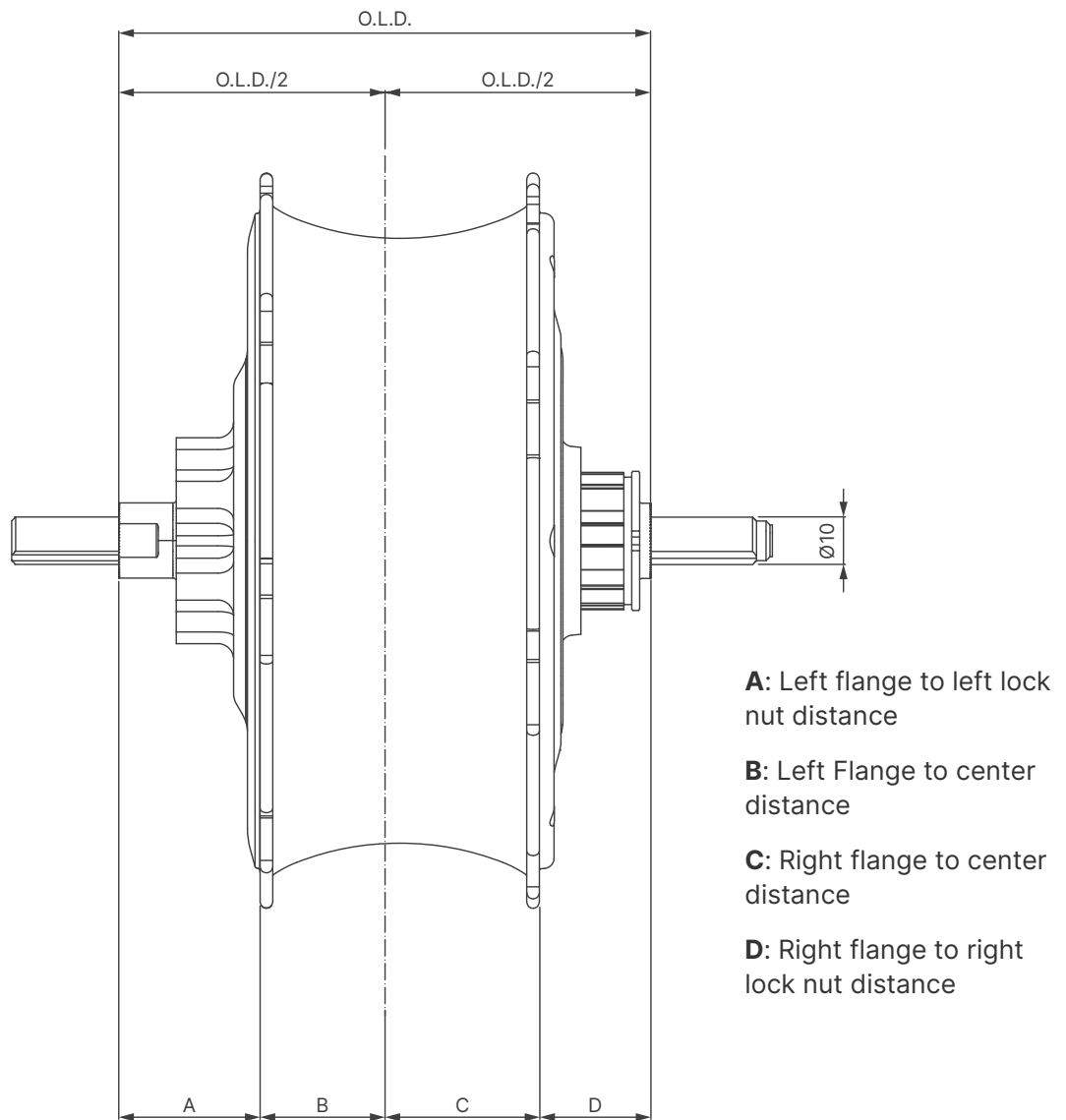

The All In One version	O.L.D.	B	C	A	D
Rim brake	120	31,3	39,3	28,7	20,7
Roller brake	135	31,3	39,3	36,2	28,2
Disc brake	135	31,3	39,3	36,2	28,2

*dimensions are in m

5. Frame building guidelines

This part of the techdocs helps in frame design starting from measures above. Customers 3D models are available on request.

This part of the manual is intended to be a guide for building a frame that suites The All In One Horizon all in one. Please read this manual carefully. Applies to all item codes.

5.1 Rear dropout design and compatibility

The All In One Horizon embeds a slope sensor that must be mounted following these manual guidelines. In order to work properly, dropouts must be horizontal, and the anti-rotation system must follow these manual guidelines.

5.1.1 Steel track dropout

Dropout shaping

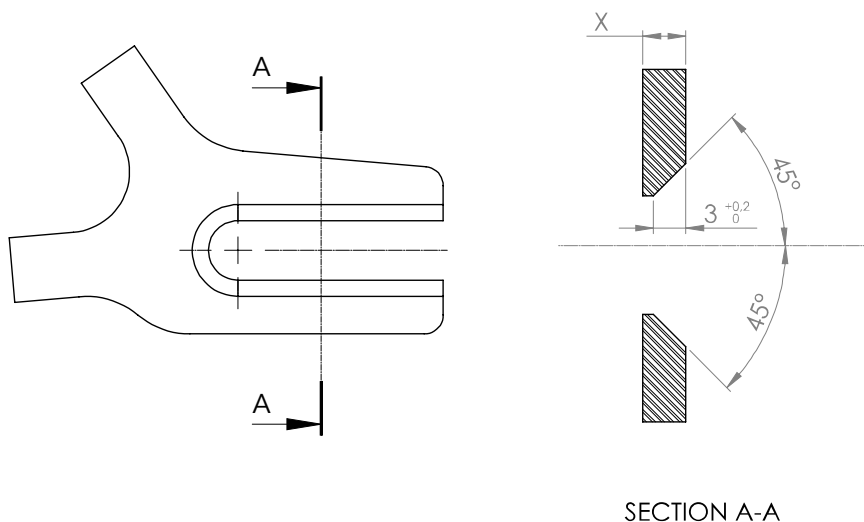

Dropout closing bracket

As the anti-rotation insert will act with a strong torque on the dropouts, a connection element between the two forks **MUST** be installed.

The instructions provided in the following figure show how to build and install a tested dropout closing bracket on a track dropout. Any suitable and equivalent solution can be adopted.

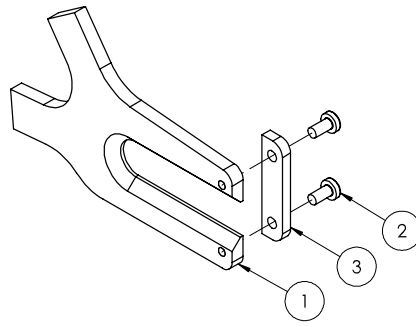

Closing bracket (3) manufacturing

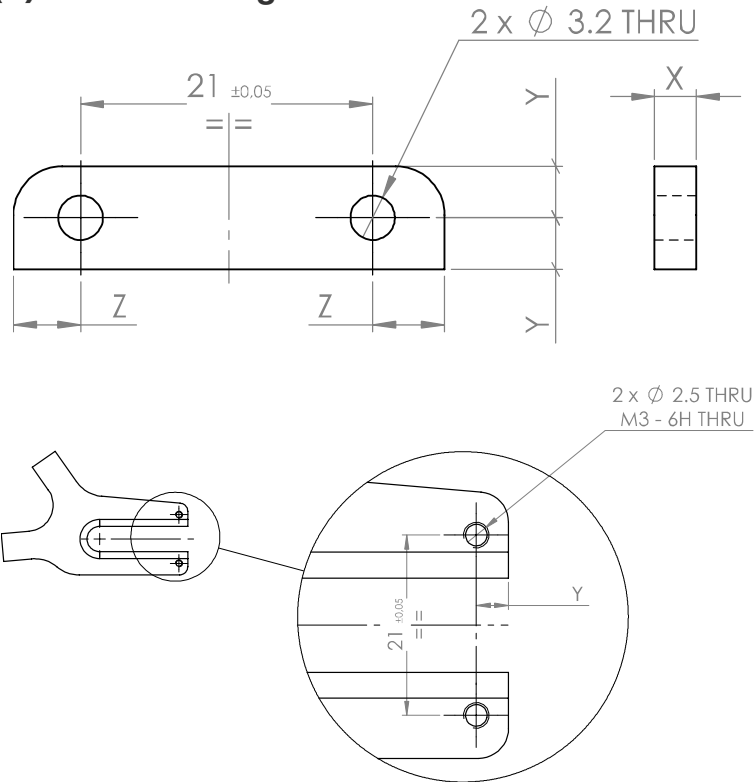

5.1.2 Horizontal steel dropout

It is not recommended to use horizontal reversed dropout with HORIZON all in one. However, some design rules for this kind of dropout are shown below.

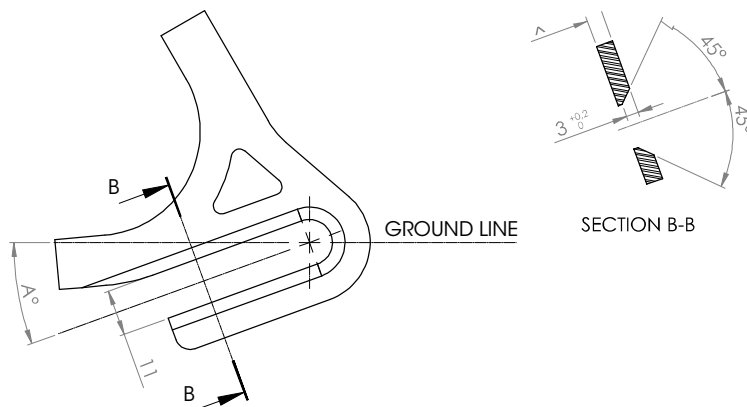

***WARNING:** the closer to 0° the better, slope sensor won't calibrate over 20°

As seen for the track dropout, a connection bracket between the fork ends is mandatory to maintain a good stiffness of the dropout itself.

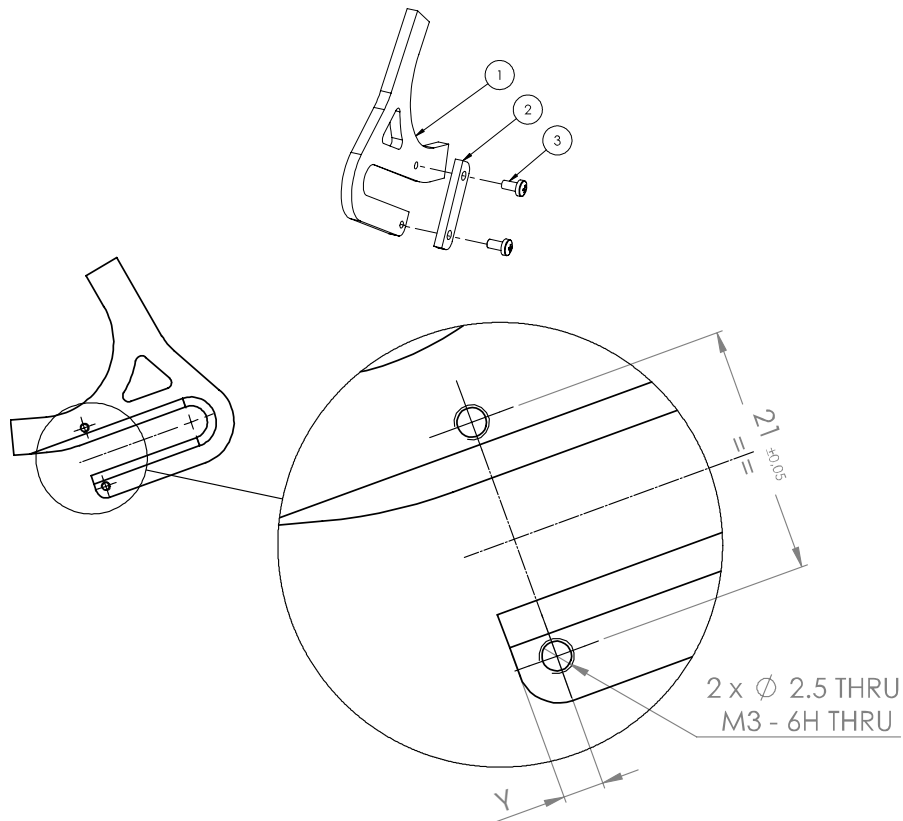

For closing bracket manufacturing see **Errore. L'origine riferimento non è stata trovata.** at page .

5.1.3 Note on vertical dropout

Vertical or Semi-vertical dropouts are NOT compatible with HORIZON all in one. Slope calibration won't work, and the hub will stop to run as the sensor will assume the bike is in a vertical position and it will turn off the assistance.

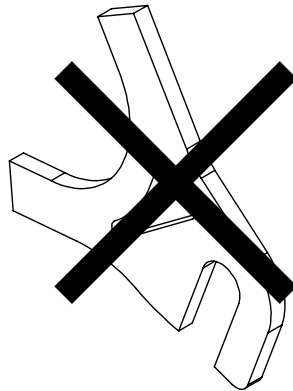

5.1.4 Aluminium track dropout

Aluminium dropouts need to be reinforced with a steel insert shaped as described below. Without the insert, the anti-rotation plate will shortly damage the dropout itself and it will be loose (so not effective).

The instructions below show also how to design, mill and drill an aluminium dropout to t a steel insert compatible with The All In One HORIZON. Any equivalent solution can be adopted.

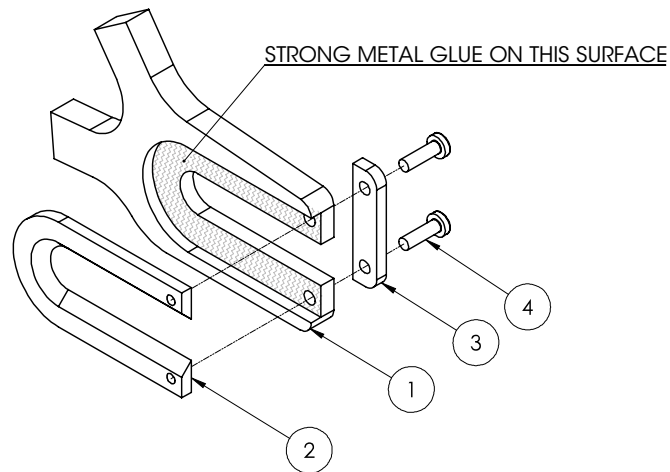

Dropout insert (2) manufacturing

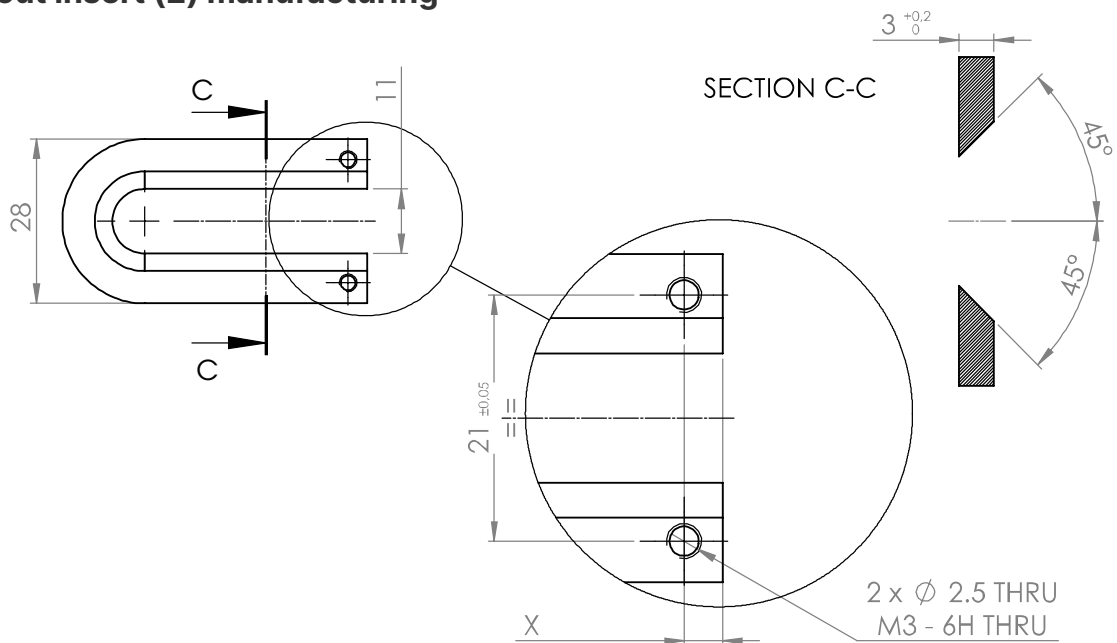

Dropout (1) shaping

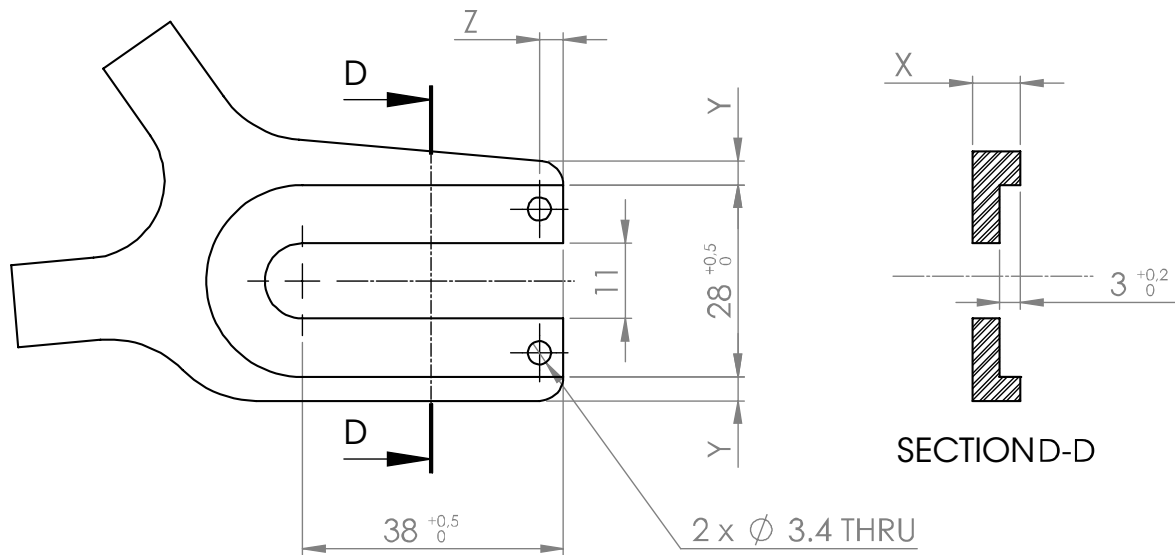

5.2 Torque arm design

Another method to prevent the hub from rotating it is the use of a proper designed torque arm.

As a torque arm highly depends on the frame geometry, the general shaping and bending lines are due to manufacturer decision.

Here below the major guidelines to build a compatible torque arm are described.

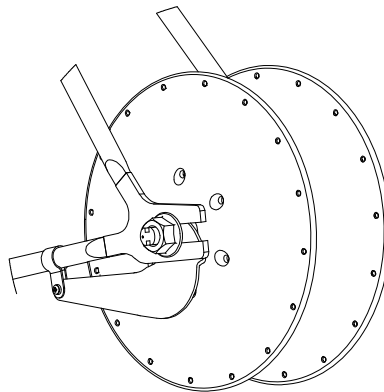

Torque arm dimensions

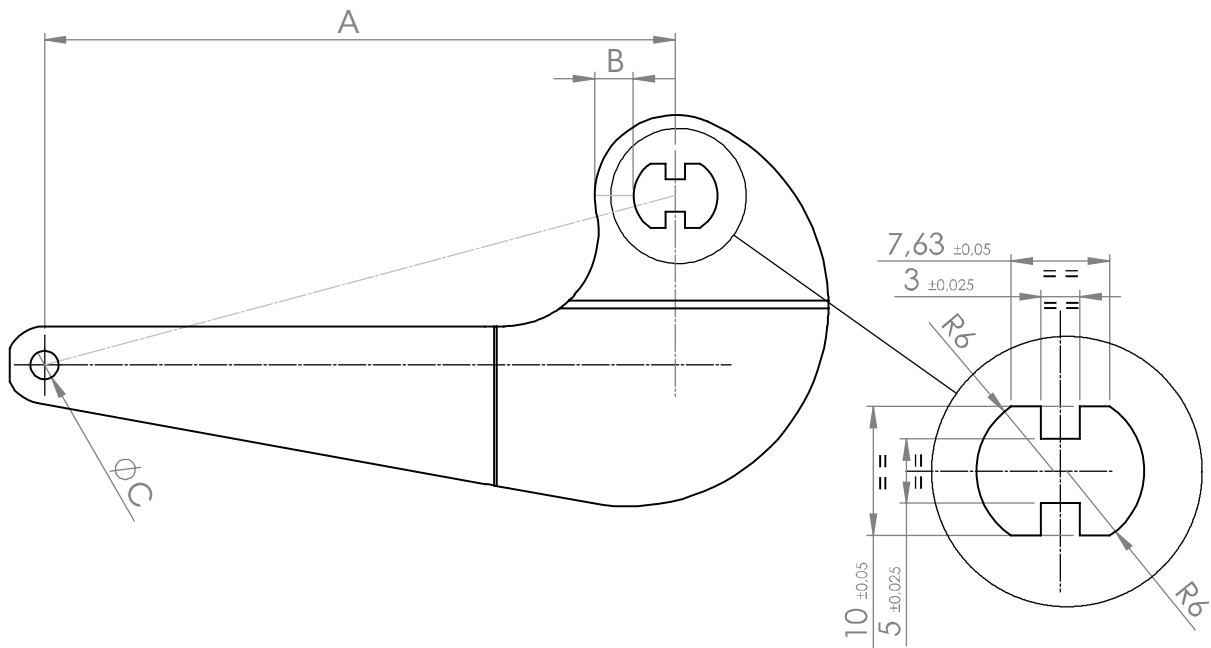

“H” cut

The “h” cut is the core of the anti-rotation system. Please follow this design rules strictly, considering the tolerances.

Torque arm shaping and bendlines

Torque arm shaping and bending depends mostly on the dropout design.

The guidelines show how to adapt the torque arm bend lines to a generic track dropout.

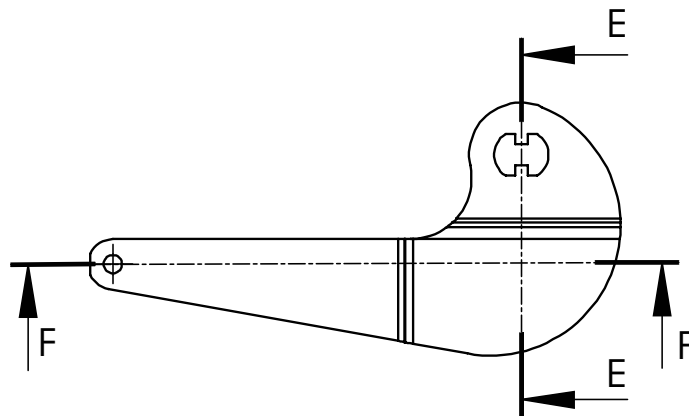

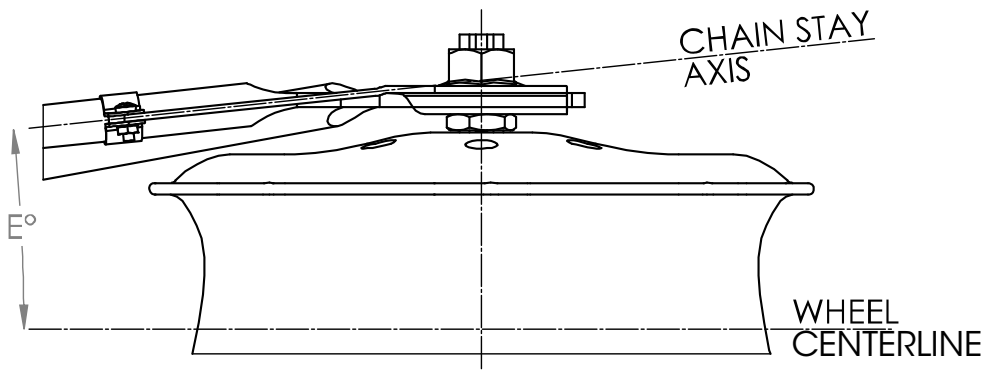
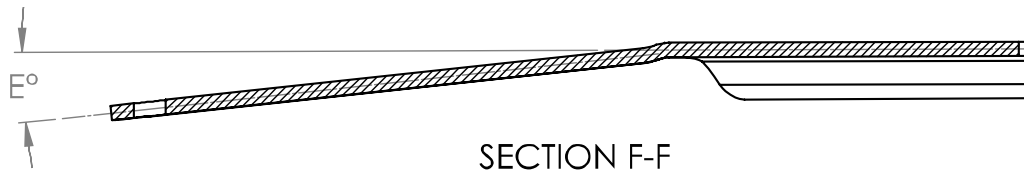
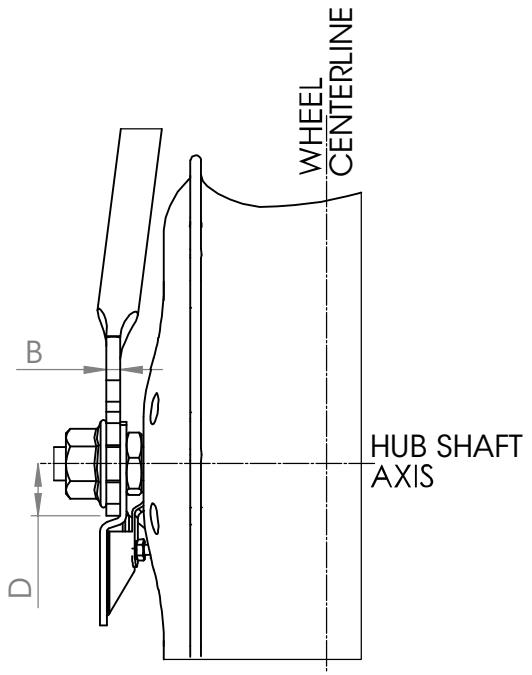
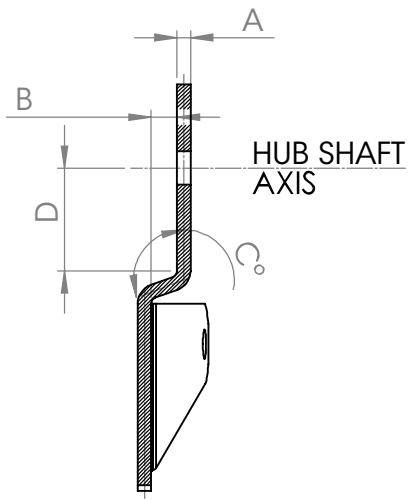

5.3 Chain stays and seat stays design

Frame builders must pay attention to the angle between the wheel centerline and both seat and chain stays, especially on the left side of The All In One.

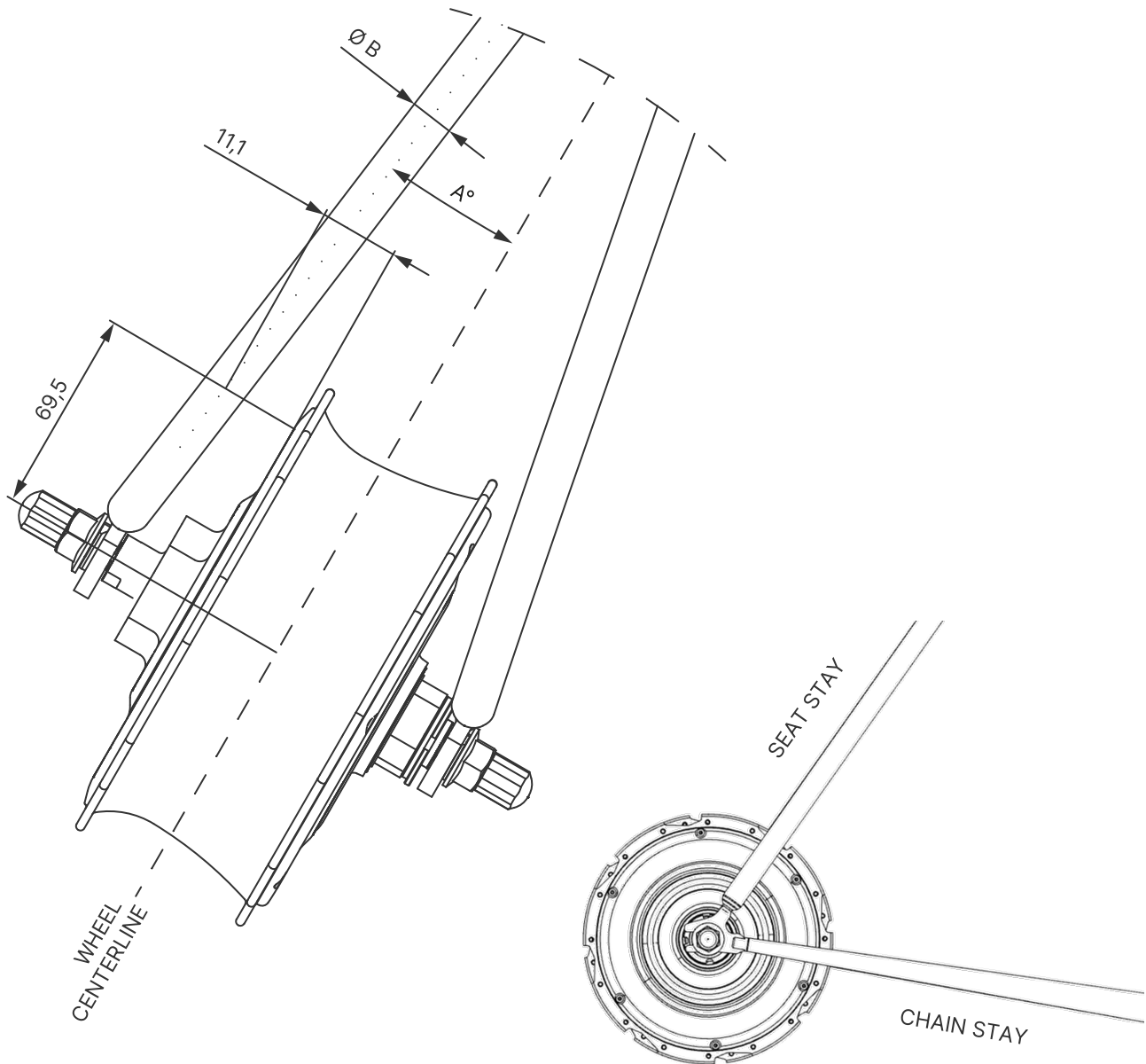

The gap between The All In One and both chain and seat stays depends on many factors, such as the angle A° , the frame pipe diameter B and the dropout shape. The advice is to use pipes with a diameter $B < 12\text{mm}$ and angle $A^\circ < 6^\circ$, using a standard track dropout. Please be careful when designing the frame.

5.4 Disc brake caliper compatibility

Please check the caliper dimensions with the brake manufacturer in order to fit correctly in the suggested distance of 2 mm between The All In One hub and the brake caliper.

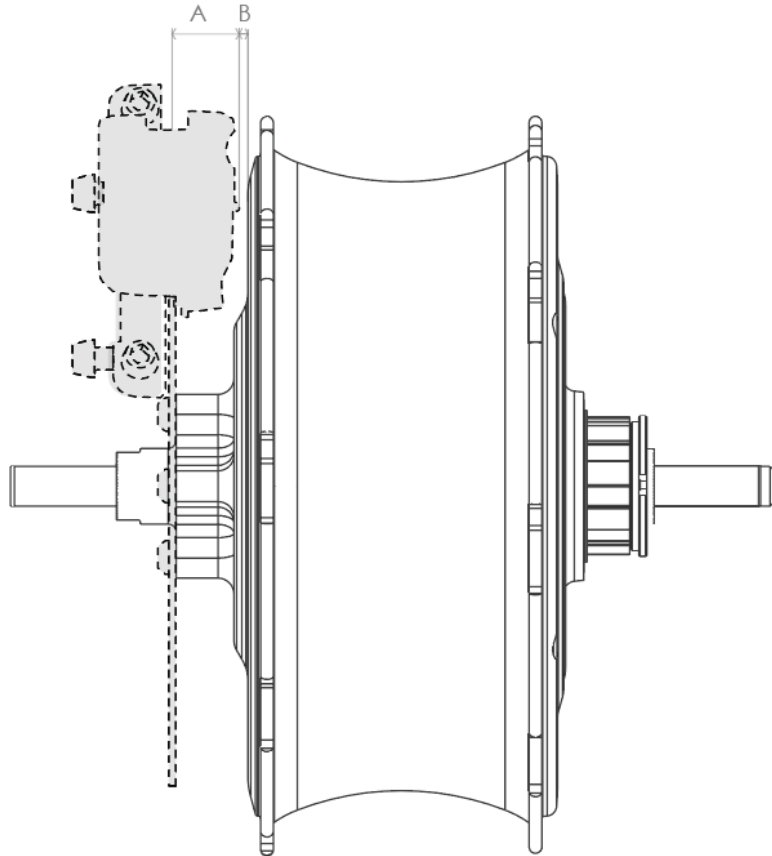

Note: please respect the clearance between the caliper and The All In One hub.

Note: please always check the dimensions of the brake calipers with the brake and adapters manufacturers.

5.5 Disc rotor compatibility

The All In One model year 2021 (Gen 2.1) is compatible with all 6-bolts IS disc rotors. The diameter of the rotor must be 160 mm or superior.

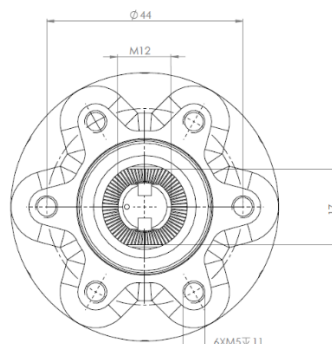

5.6 Disc brake mount dimensions

Please refer to the INTERNATIONAL STANDARD / POST MOUNT / FLAT MOUNT manuals to design or purchase the correct adaptor for The Zehus All In One system.

Attention: please always check The All In One hub dimensions to determine the final disc and caliper position.

5.7 Rollerbrake® compatibility

The Roller brake version of The All In One is compatible with Rollerbrake® drum brakes.

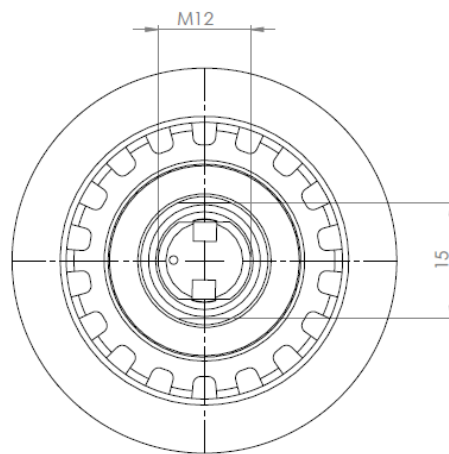

Zehus provides a HEX nut M12x1.25 – H19x7 according to ISO DIN936.

Thickness for this nut is 7 mm. Please ensure that your frame is compatible with this spacing.

6. Assembly instructions

6.1 Content of the box

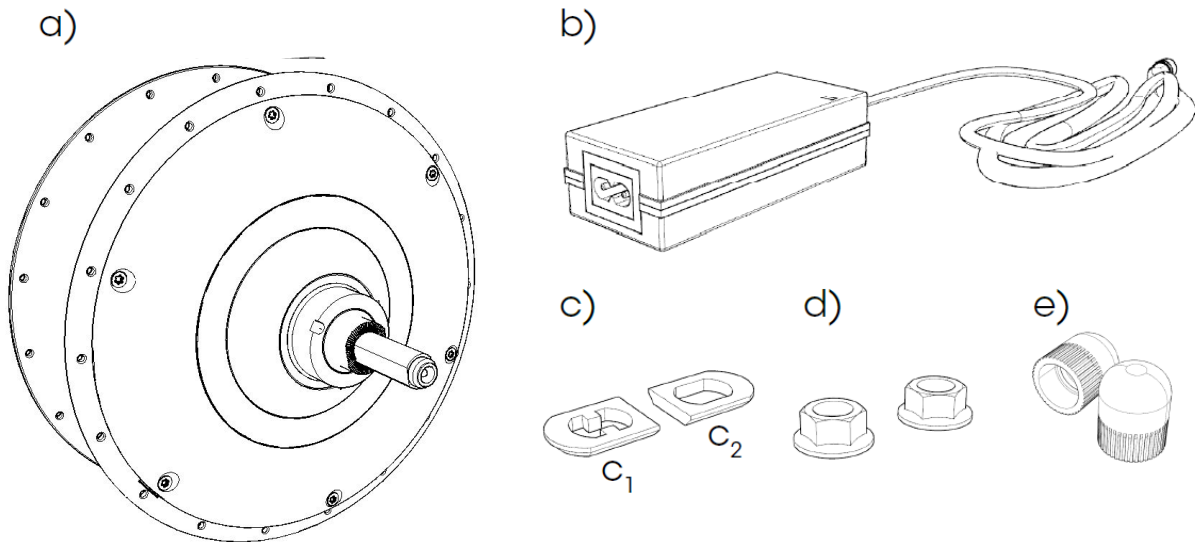

*check the content of the box. If anything is missing, please contact us (customerservice@zehus.it)

Anti rotation kit (to be ordered separately)**

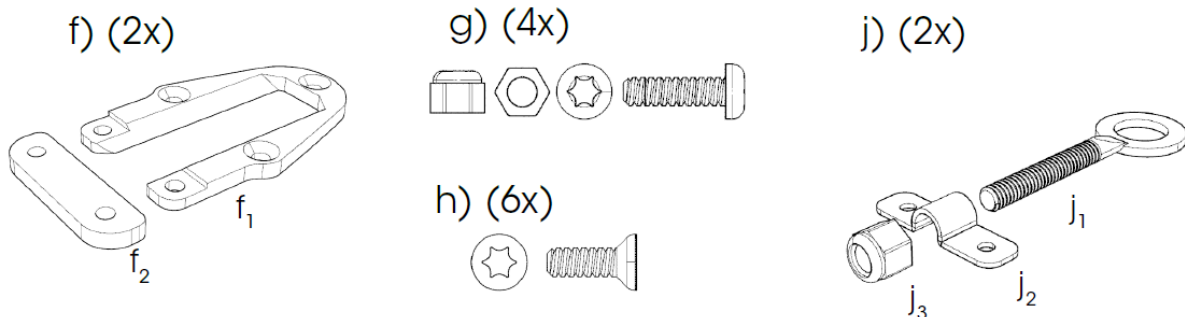

**if you produce your anti-rotation kit according to Zehus Guidelines, figures in this manual can be different from your own application

6.2 Wheel building (lacing)

The All In One Bike is compatible with rims from 20 inches on. For 16 inches wheels, custom motor and custom lacing should be produced; please contact directly your Zehus sales contact. For further information please contact us at customerservice1@zehus.it.

Evaluating the correct spoke length

In order to evaluate the spoke length to lace the wheel please refer to the measurements of your model. Please double check the item code to match with the chart provided above. You can then use a standard manual or an online calculator (e.g. SAPIM spoke calculator).

EN15194 Configuration

the following configuration has been successfully tested under the EN15194 conditions:

Rim	Tire	Tube	Spokes
Ambrosio Keba 28"	Schwalbe Marathon Plus 700x28c	Butyl 700x28c	Steel 2.3 mm tapered 2 mm

Zehus, formerly Zehus, is not responsible for the assembly of any wheel with different configuration than the one shown above. If your wheel configuration includes different components or different sizes or qualities from the ones listed above, it will be necessary to perform a preventive validation carried out by an expert wheel builder (that includes EN15194 test) before selling the vehicle to any end consumer").

Important information

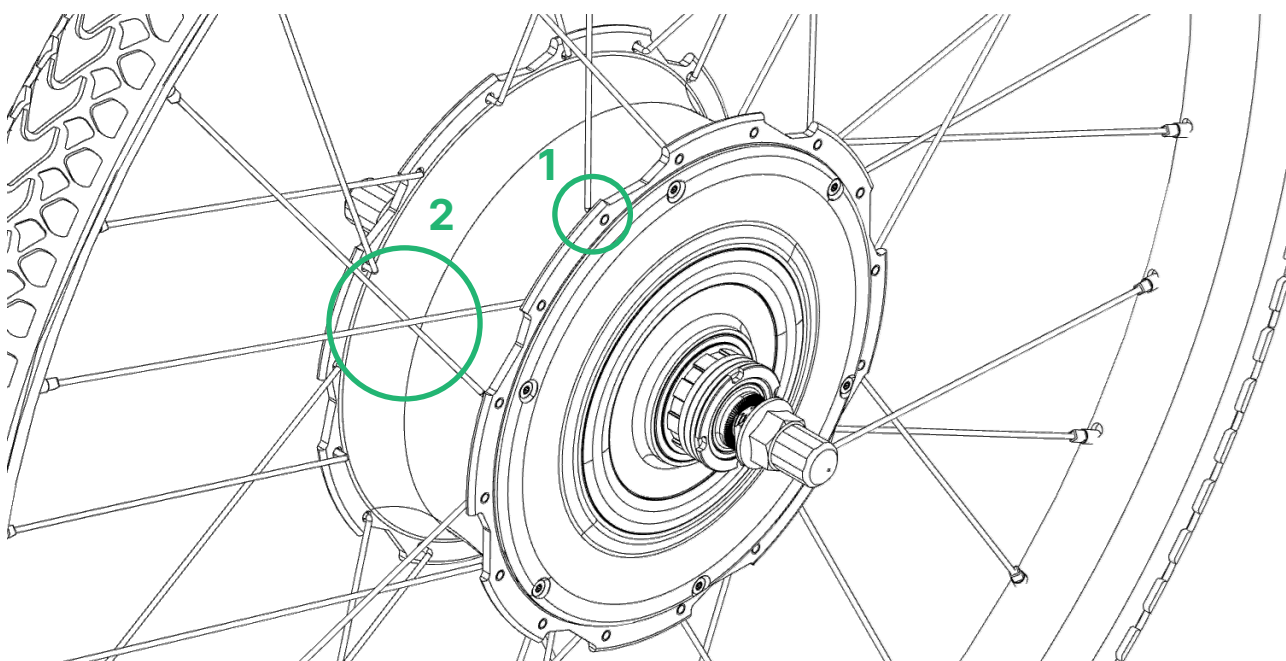

Attention: Zehus strongly recommends inserting the spokes from OUTSIDE to INSIDE the spoke hole (1).

Attention: Zehus strongly recommends building 1-cross wheels for 24"-29" wheels (2), instead 16"-20" wheels should be laced with radial spoking (0-cross).

RIGHT SIDE (SPROCKET SIDE)

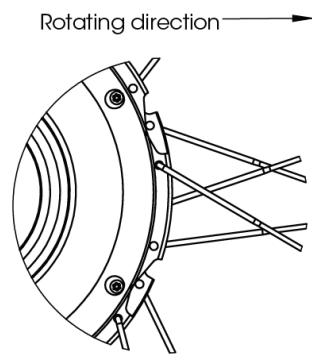

LEFT SIDE (DISC SIDE)

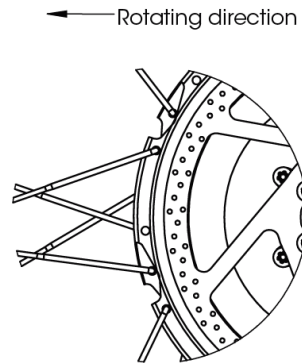

6.3 Mounting the wheel on the frame

Step 1

Only if you are applying Zehus Anti-rotation kit. Prepare the frame drilling holes for placing the anti-rotational plates. Then secure the anti-rotational plates (f1) firmly to the frame rear fork using 3 M3-torx head screws (h) per each plate:

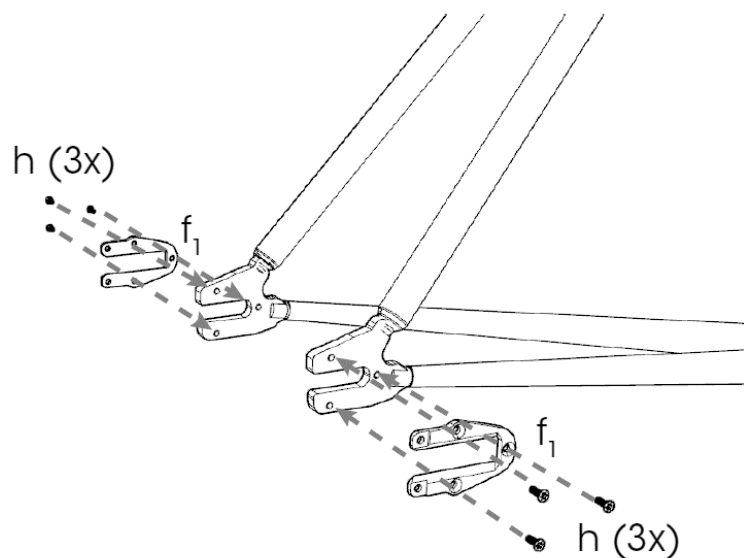

Step 2

Insert the wheel in the rear fork and put the chain on the cog. Please be careful. The forward direction of the hub is marked on the left side of the axle.

Please insert the wheel in the correct side, OTHERWISE HORIZON WILL NOT WORK!

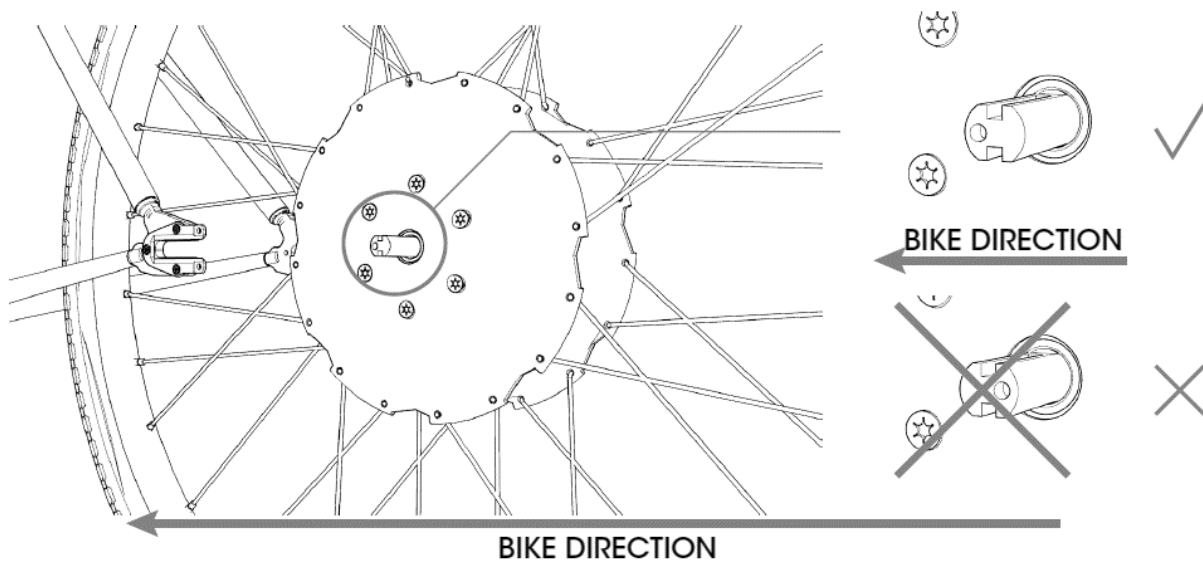
**Step 3**

Insert the proper anti-rotation adaptor (c1-c2) on the axle. c1 must be inserted on the left axle and c2 must be inserted on the right axle.

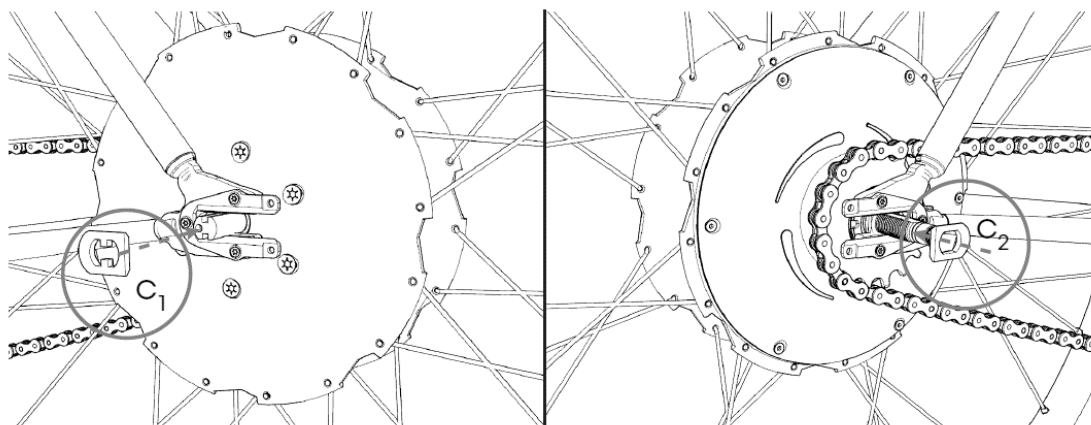

Step 4

Only if you are applying Zehus Anti-rotation kit. Place the chain tensioner (j1) onto the shafts and make the lock plates (f2 - j2) firm with the anti-rotational plates (f1) using the proper screws and self-locking nuts (g)

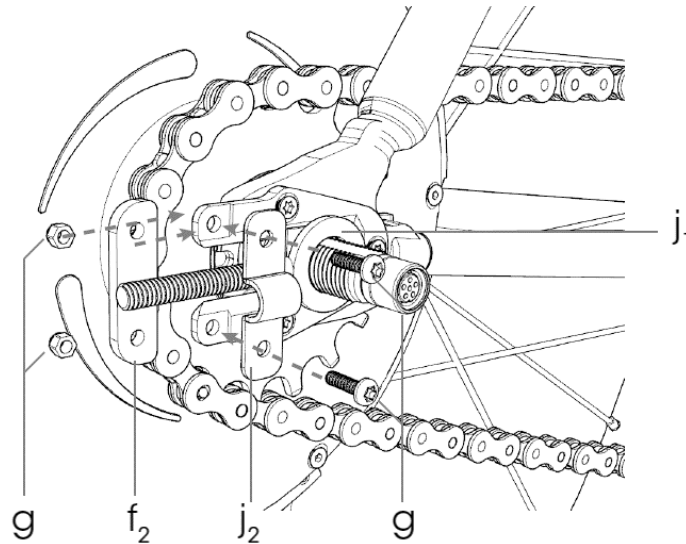
**Step 5**

5A: Only if you are applying Zehus Anti-rotation kit. Using the chain tensioner nut (j3), place the wheel in the correct position to guarantee a good tension on the chain.

5B: If you do not use Zehus Anti-rotation kit, please take care to apply the correct tension to the bike chain.

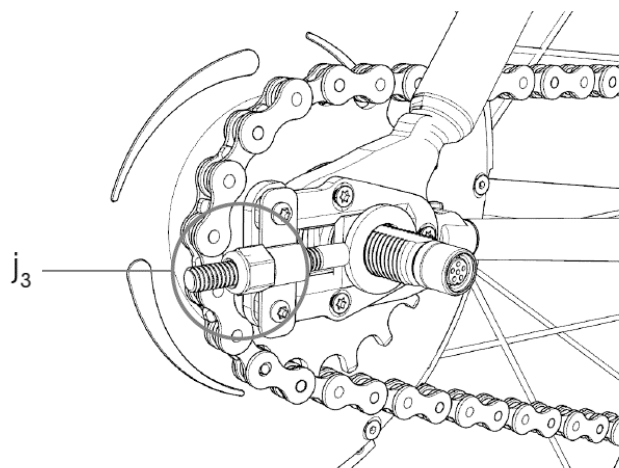

Step 6

Tighten the hub self-locking nuts (d) up to **30 Nm**.

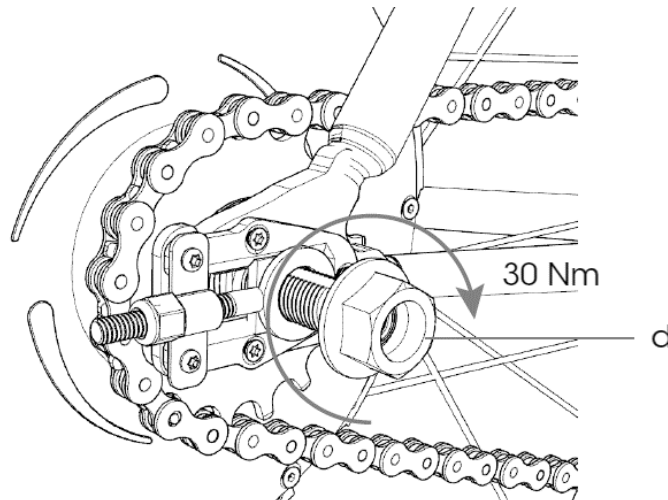
**Step 7**

Cover and protect the charge connector with the close nut (e).

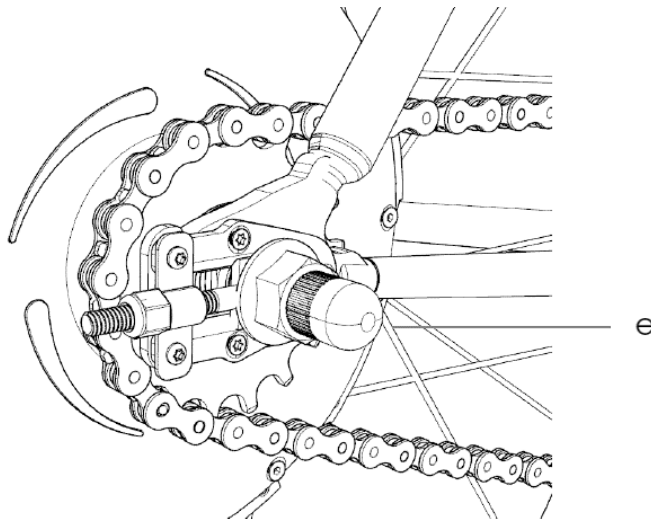

ALWAYS RIDE THE BIKE WITH THE CLOSE NUTS (e). Damages occurred to the connector due to the lack of the close nuts is not covered by warranty.

7. Sprockets and gearbox compatibility

The All In One model year 2021 (Gen 2.1) freewheel system is compatible with Shimano HG-Splines sprockets, a custom lockring is provided, and it may be necessary the use of spacers to adjust the sprocket for the correct chainline.

7.1 Lockring and lockring tools

In case of multi speed applications, the provided lockring is the following:

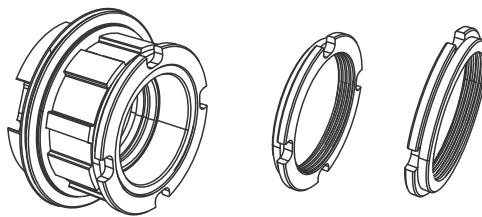

Then, first cassette sprocket should be an 11T.

In case of single speed applications, last sprocket spacer should be a 9 splined spacer like the following:

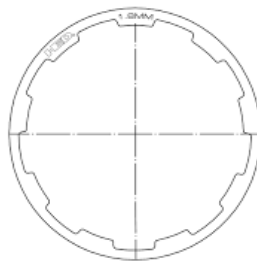

Tightening torque for any freewheel Lockring is 40 Nm. Please make sure that your lockring is correctly tightened to guarantee the correct functioning of the system.

It is possible to request the lockring M0781300 specifically designed for single speed applications. This lockring is compatible with standard cassette spacers.

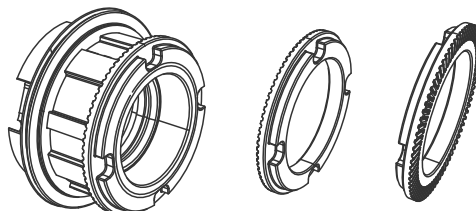

Single Speed Lockring

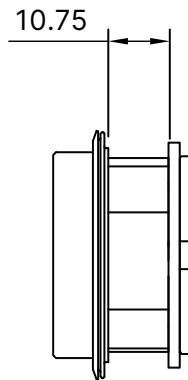

Zehus developed a tool to tighten this type of lockring with a H17 wrench. Please inquire with Sales for Price, Availability and Lead time.

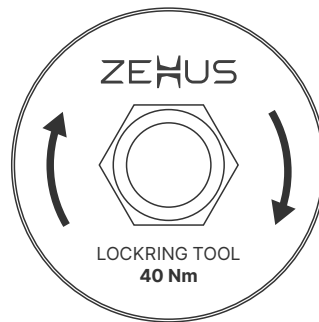

For Single Speed versions, Zehus lockring can be tightened using a Hook Spanner. This tool is specific for certain diameters. Please make sure your Hook Spanner is compatible with a 37 mm diameter.

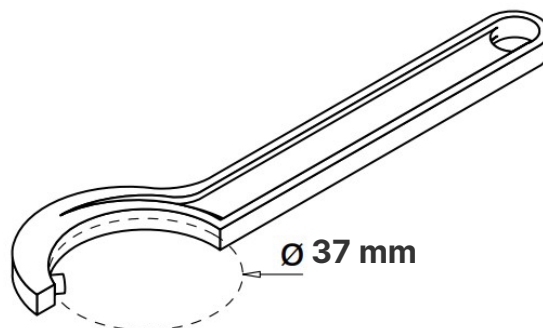

7.2 Gearbox systems

The All In One Halos embeds:

- Safety turn on button: this button is available on the smartphone app and on the Remote Controller. If the customer does not want to use the app, procedure to activate the bike requires to pedal backwards per 3 revolutions at a speed faster than 10 Km/h.
- KERS – regenerative braking capabilities. KERS is activated by pedaling backwards or via Remote control.

All the system that inserts a freewheeling between the chain and Zehus hub are not compatible with the 2 functions mentioned above. Please notice that all Pinion gearbox systems feature a freewheeling system!

Here below you can find a list of front gearboxes without internal freewheeling system and their main features*

Product	Gears	Weight (kg)	Ratio	Website
Efneo	3	1,200	1,79:1,43:1	http://www.efneo.com/gearbox/
Habelstock Schlumpf	2	0,900	1,65:1 or 2,5:1	http://www.haberstock-mobility.com/index.php/products.html

**Products specs can change without notice. Please check on the producer's website*

8. Battery care

It is important to take care of the battery embedded in The All In One to maximize its durability and capacity.

8.1 Charging

Always charge the battery of your All In One to avoid full discharge that could damage its power. Please follow the instruction contained on the label of the battery charger. It is recommended to charge the battery in a safe environment, clean and protected by water. It is recommended not to charge the battery at night.

8.2 Storage conditions

The All In One has to be stored at the right temperature. The battery pack life can be maximized by following the rules for correct storage and handling. In case of malfunctioning your battery pack will have to be replaced. Please refer to a Zehus retailer to have your battery pack replaced.

Note: when not using the bike for long periods it is recommended to charge the battery pack to 60% and to check the battery condition at least every 6 months. Before using the bike after a long period it is recommended to fully charge the battery.

Store All In One in a well-ventilated location, dry if possible. Protect the hub from moisture and water. The optimal storage temperature is +23°C and the bike must be stored between 0°C and +40°C. It is preferred not to leave the bike under the direct sunlight during hot summer days.

8.3 Transport

Items with internal battery packs are subject to Dangerous Goods Legislation requirements. Private users can transport such undamaged items by road without further requirements.

When being transported by commercial users or third parties (e.g. air transport or FWD agencies), special requirements on packaging and labeling must be observed (e.g. ADR regulations). If necessary, an expert for hazardous materials can be consulted when preparing the item for shipping.

Dispatch The All In One only when the housing is undamaged. Protect the charger connector with the provided closed nut in such a manner that the connector itself cannot be damaged or broken. Inform your parcel service that the package contains dangerous goods. Please also observe the possibility of more detailed national regulations. In case of questions concerning transport of The All In One, please refer to an authorized Zehus dealer. Bicycle dealers can also provide suitable transport packaging.

8.4 Disposal

The All In One and all its components should be sorted for environmental-friendly recycling.

Only for EC countries

According to European Guideline 2012/19/EU, electrical devices tools that are no longer usable, and according to European Guideline 2006/66/EC, defective or used battery packs/batteries. The All In One must be collected separately and disposed of in an environmentally correct manner.

Warnings*Handling of Li-Ion battery cells - risks and precautions*

The user must have appropriate understanding of lithium-ion batteries before purchase.

Use caution when working with and using lithium-ion batteries as they are very sensitive to charging characteristics and may explode, burn, or cause a fire if misused or mishandled.

Always charge in or on a fire-proof surface. Never leave batteries charging unattended.

The batteries are sold for the use of system integrations with proper protection circuitry or battery packs with a battery management system or PCB (circuit board/module).

Buyer is responsible for any damage or injury caused by misuse or mishandling lithium-ion batteries and chargers.

Charge only with appropriate charger designed by ZEHUS for this specific type of lithium-ion battery pack.

- MISUSING OR MISHANDLING LITHIUM-ION BATTERIES CAN POSE A SERIOUS RISK OF PERSONAL INJURY, PROPERTY DAMAGE, OR DEATH
- BATTERIES MAY EXPLODE, BURN, OR CAUSE A FIRE IF MISUSED OR MISHANDLED
- ONLY USE WITH PROPER CIRCUITRY IN A PROTECTED BATTERY PACK
- ONLY USE WITHIN MANUFACTURER LISTED SPECIFICATIONS
- DO NOT STORE LOOSE BATTERY IN A SIMPLY CARTON BOX - ALWAYS USE A PROTECTIVE CASE OR BOX
- KEEP AWAY from metal objects to prevent short circuiting
- DO NOT short circuit

- DO NOT use if wrapper or insulator is damaged or torn
- DO NOT use if damaged in any way
- DO NOT overcharge or over-discharge

- DO NOT modify, disassemble, puncture, cut, crush, or incinerate

- DO NOT expose to liquids or high temperatures

- DO NOT solder, spot weld only

- User must be familiar with handling lithium-ion batteries before purchase

- Usage of batteries is AT YOUR OWN RISK

- ALWAYS charge in or on a fire-proof surface and never leave charging batteries unattended

- RESELLERS MUST FORWARD ALL WARNINGS TO ALL CUSTOMERS FOR THEIR REFERENCE AND SAFETY

Local regulations and laws pertaining to the recycling and disposal of lithium ion batteries vary so please consult your local jurisdiction regarding appropriate disposal.

HUMAN PLUS